

Servo Insert Coupling

with collet clamps

optional full stainless steel version

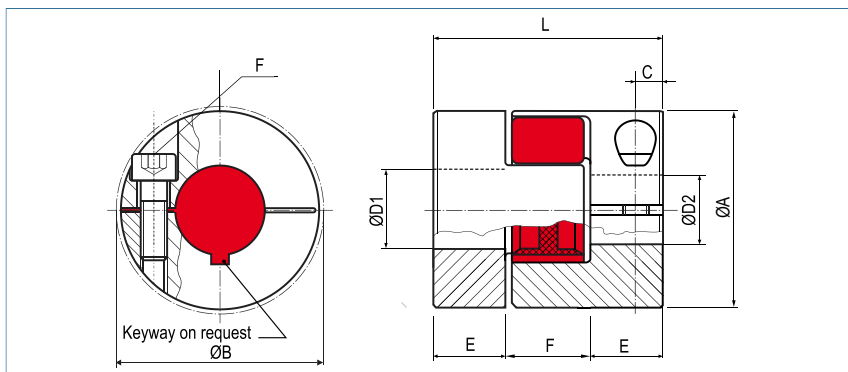

Order Code

KBE2 - 14 - 10 - 12 - 98Sh

Type Size ØD1 (H7) ØD2 (H7) Shore-hardness

Size	Dimensions (mm)								Technical Data			
	ØA Outer Ø	L Length	Ø D1-D2 Bore Sizes (H7) min-max	E	F	C	B	F Screw (ISO4762) TA (Nm)	max. speed rpm. (1/min)	Mass (per coupling) (g)	Moment of Inertia (per coupling) J (g m²)	Torque (Nm)
5	10	15	2 - 5	5	5	2.5	11.4	M1.6 0.25	38000	2.52	0.000036	0.5
7	14	22	4 - 7	7	8	3.5	15	M2 0.43	27000	7	0.000195	1.2
9	20	30	4 - 11	10	10	5	23.4	M2.5 0.85	19000	18.52	0.00107	3
14	30	35	4 - 16	11	13	5	32.2	M3 2	13000	59	0.00381	12.5
19	40	66	10 - 22/24*	25	16	12	47	M6 15	10000	183	0.0404	17

Ø Bore Size (mm)																							
Size	2	3	4	5	6	7	8	9	10	11	12	13	14	15	16	17	18	19	20	21	22		
5	06	0.6	0.7	0.8																			
7			1.3	1.4	1.5	1.6																	
9			2.3	2.4	2.5	2.7	2.8	2.9	3.0	3.2													
14			7.7	8.0	8.3	8.6	8.9	9.2	9.4	9.7	10	10.3	10.6	10.9	11.2								
19											44	45	47	48	49	50	51	52	54	55	56	57	58

+ **Material** hub - aluminium
 spider element - polyurethane
Hub bore tolerance: H7
Keyway optional acc. DIN 6885
Shore-hardness bis size 9: 92 Sh A (yellow)
 ab size 14: 98 Sh A (red)

* Hubs for bores > 22H7 to 24H7 will be supplied with 2 x M4 screws.
 Further spider elements and technical data are available on page 42.

Servo Insert Coupling

with collet clamps

optional full stainless steel version

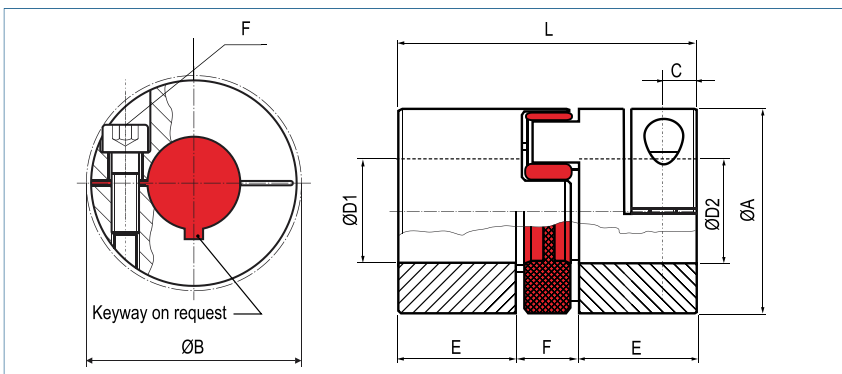

Order Code

KBE2 - 38 - 20 - 40 - 98Sh

Type Size ØD1 (H7) ØD2 (H7) Shore-hardness

Size	Dimensions (mm)								Technical Data			
	ØA Outer Ø	L Length	Ø D1-D2 Bore Sizes (H7) min-max	E	F	C	B	F Screw (ISO4762) TA (Nm)	max. speed rpm. (1/min)	Mass (per coupling) (g)	Moment of Inertia J (per coupling) (g m²)	Torque (Nm)
24	55	78	15 - 32	30	18	12	56.4	M6 15	7000	394	0.175	60
28	65	90	19 - 37	35	20	15	72.6	M8 40	6000	624	0.377	160
38	80	114	20 - 48	45	24	20	83.3	M8 40	5000	1230	1.139	325
42	95	126	25 - 50	50	26	20	95	M10 84	4000	1960	2.505	450
48	105	140	25 - 57	56	28	22	105	M12 145	3750	2690	4.175	525

Size	Ø Bore Size (mm)																												
	15	16	19	20	22	24	25	28	30	32	35	38	39	40	41	42	43	44	45	46	47	48	49	50	51	52	53	54	
24	64	65	69	70	72	74	76	79	81	84																			
28			114	116	119	123	124	130	133	137	142																		
38				135	138	142	144	149	152	156	161	166	168	169	171	173	175	176	178										
42							294	304	310	317	327	337	340	343	347	350	353	357	360	363	367	370	373	376					
48							476	491	500	510	524	539	544	548	553	558	563	568	572	577	582	587	592	596	601	606	611	616	

+ **Material** hub - aluminium
 spider element - polyurethane
Hub bore tolerance: H7
Keyway optional acc. DIN 6885
Shore-hardness 98 Sh A (red)
 Further spider elements and technical data are available on page 42.