

## Safety Coupling

with two collet clamps

optional  
nickel-plated version  
optional full stainless  
steel version

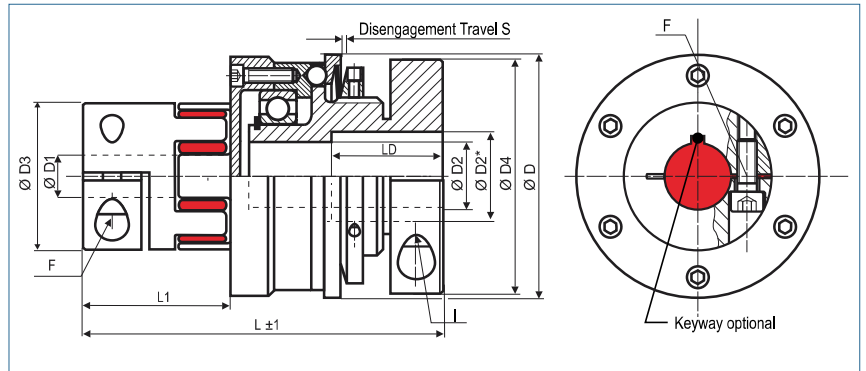

Order Code

**KBK/EKK - 24 - 126.5 - 16H7 - 14H7 - 20Nm - C or D - 2**

Type                      Size                      Length                      ØD1 (H7)                      ØD2 (H7)                      Disengagement Torque                      Torque Range

C = Single Position    D = Multi Position Engagement

Size	Dimensions (mm)										Technical Data								
	ØD	L	Ø D1	Ø D2	Ø D3	Ø D4	F	I	L1	S	max. speed (1/min)	Mass (kg)	Moment of Inertia J (kg cm <sup>2</sup> )	Torque 98 Sh TKN (Nm)	Torque Range		Misalignment		
	Outer Ø	Length	Bore Size (H7) min-max	Bore Size (H7) min-max			Screw ISO4762 TA (Nm)	Screw ISO4762 TA (Nm)							1 TKN (Nm)	2 TKN (Nm)	radial Δ Kr (mm)	axial Δ Ka (mm)	angular Δ Kw (°)
-14	49	65	4-16	6-16 11#	30	40.5	M3 1.4	M4 5.1	24	0.7	11690	0.24	0.6	12.5	3 - 7	5 - 10	0.09	+1.0 -0.5	0.9
-19	64	100 92	10-22	10-20 14#	40	56	M6/11 M6/11	M6 15	41 33	1.2	8950	0.79	3.2	17	5 - 15	10 - 30	0.06	+1.2 -0.5	0.9
-24	79	126.5 116.5	15-32	12-28 21#	55	66	M6/11 M6/11	M8 36	50 40	1.2	7630	1.46	8.9	60	12 - 35	20 - 60	0.10	+1.4 -0.5	0.9
-28	94	142 128	19-38	14-35 27#	65	82	M8/25 M8/25	M10 72	59 45	2	6030	3.1	27	160	50 - 130	65 - 150	0.11	+1.5 -0.7	0.9
-38	119	160 146	20-45	30-50 41#	80	110	M8/25 M10/49	M12 125	67 59	2	4980	5.7	86	325	60 - 200	150 - 300	0.12	+1.8 -0.7	0.9
-42	129	195	28-45	35-56 46#	95	122	M10 70	M12 125	76	2	4440	8.5	150	450	80 - 250	200 - 500	0.14	+2.0 -1.0	0.9



**Bores** > Ø D2 and ≤ D2\* only over LD

**Material** collet clamp: aluminium  
spider element: polyurethane 98 Sh A (red)

**Hub Style** size 14 and 19: single slit\*\*  
size 24, 28, 38 and 42: double slit  
\*\* short lengths are automatically with single slits

**Keyway** optional acc. DIN 6885  
biggest bore marked with a #

**Temperature Range** -30 °C ~ 90 °C

Size	14	19	24	28	38	42
D2*	20	26	31	38	57	62
LD	20	28	38	34	42	56