

Safety Coupling

with inner cone and two bearings

optional
nickel-plated version
optional full stainless
steel version

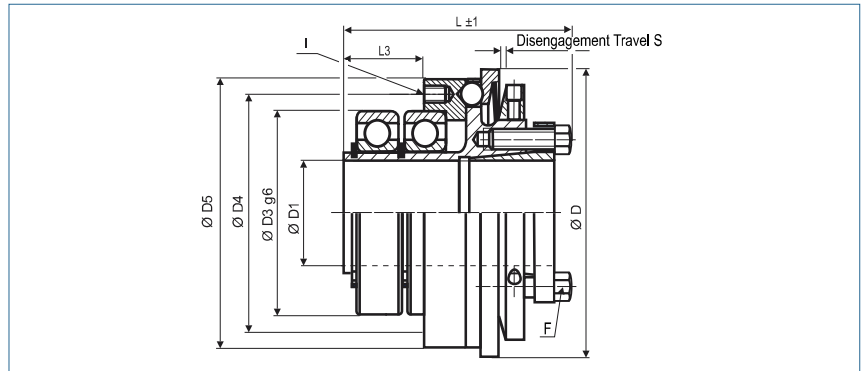
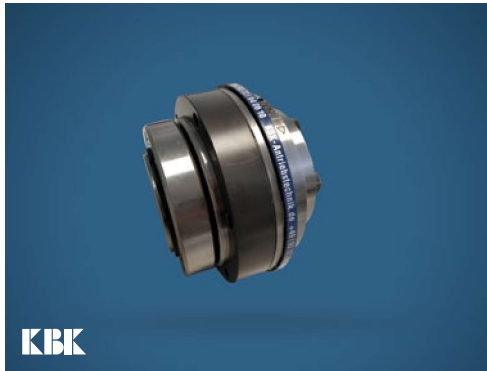

Order Code

KBK/LL-I - 60 - 20H7 - 20Nm - C or D - 2

Type . Size

ØD1 (H7)

Disengagement Torque

Torque Range

C = Single Position D = Multi Position Engagement

Size	Dimensions (mm)										Technical Data				
	ØD	Ø D1	Ø D3	Ø D4	Ø D5	L	L3	S	I	F	Torque Range		max. speed (1/min)	Mass (kg)	Moment of Inertia J (kg cm ²)
	Outer Ø	Bore Size (H7) min~max				Length			6x	Screw (ISO4017) T _A (Nm)	1 T _{KN} (Nm)	2 T _{KN} (Nm)			
-10	49	6-14 10#	37	42	47	46	15	0.7	M3	M3 2.1	3-7	5-10	12000	0.21	0.5
-30	64	12-20 14#	47	53	60	58	20	1.2	M4	M5 6	5-15	10-30	9400	0.62	2.6
-60	79	15-25 18#	62	69	75	75	26	1.2	M5	M6 8.5	13-35	20-65	7800	1.16	7.1
-80	94	20-35 27#	68	80	90	76	27	2	M6	M6 14	15-40	30-80	6400	1.97	17
-150	94	20-35 27#	68	80	90	76	27	2	M6	M6 14	50-130	65-150	6400	1.97	17
-200	109	20-40 32#	80	90	105	85	28	2	M6	M6 14	30-90	80-200	5500	2.30	27
-300	119	25-45 37#	90	102	115	95	31	2	M8	M8 20	60-200	150-300	5000	3.7	56
-500	129	35-55 45	100	112	125	95	31	2	M8	M8 26	80-250	200-500	4500	5.3	95
-800	169	50-70 58#	110	125	165	133	38	2	M12	M16 45	260-600	500-900	3500	15	438
-1400	169	50-70 58#	110	125	165	133	38	2	M12	M16 80	450-900	800-1400	3500	15	438



Keyway

optional acc. DIN 6885

biggest bore marked with a #

Temperature Range

-30 °C ~ 120 °C