

Safety Coupling

with inner cone

optional
nickel-plated version
optional full stainless
steel version

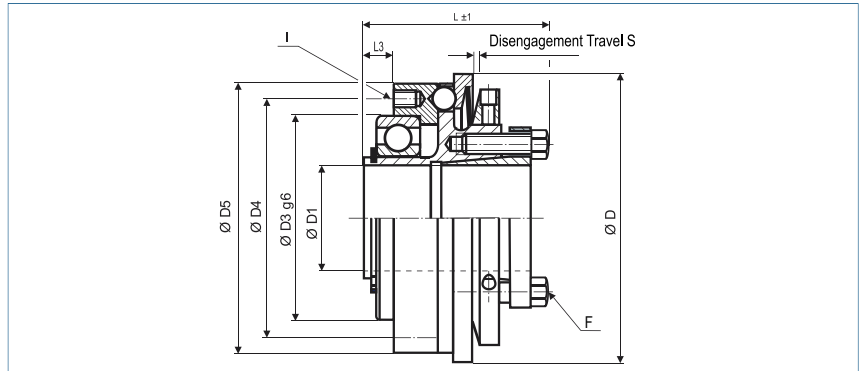

Order Code

KBK/L-I - 60 - 20H7 - 20Nm - C or D - 2

Type

Size

ØD1
(H7)

Disengagement
Torque

Torque
Range

C = Single Position D = Multi Position Engagement

Size	Dimensions (mm)										Technical Data				
	ØD	Ø D1	Ø D3	Ø D4	Ø D5	L	L3	S	I	F	Torque Range		max. speed (1/min)	Mass (kg)	Moment of Inertia J (kg cm ²)
	Outer Ø	Bore Size (H7) min~max				Length			6x	Screw ISO4017 T _A (Nm)	1 T _{KN} (Nm)	2 T _{KN} (Nm)			
-10	49	6-14 10#	37	42	47	36	5	0.7	M3	M3 2.1	3-7	5-10	12000	0.18	0.4
-30	64	12-20 14#	47	53	60	45	6	1.2	M4	M5 6	5-15	10-30	9400	0.54	2.2
-60	79	15-25 18#	62	69	75	58	8	1.2	M5	M6 8.5	13-35	20-65	7800	1.01	6.2
-80	94	20-35 27#	68	80	90	60	10	2	M6	M6 14	15-40	30-80	6400	1.72	15
-150	94	20-35 27#	68	80	90	60	10	2	M6	M6 14	50-130	65-150	6400	1.72	15
-200	109	20-40 32#	80	90	105	66	10	2	M6	M6 14	30-90	80-200	5500	2	24
-300	119	25-45 37#	90	102	115	75	10	2	M8	M8 20	60-200	150-300	5000	3.3	49
-500	129	35-55 45#	100	112	125	75	10	2	M8	M8 26	80-250	200-500	4500	4.7	83
-800	169	50-70 58#	110	125	165	110	15	2	M12	M16 45	260-600	500-900	3500	13.1	380
-1400	169	50-70 58#	110	125	165	110	15	2	M12	M16 80	450-900	800-1400	3500	13.2	385



Keyway

optional acc. DIN 6885

biggest bore marked with a #

Temperature Range

-30 °C ~ 120 °C